

(No Model.)

3 Sheets—Sheet 1.

A. MILES.
ELEVATOR.

No. 371,207.

Patented Oct. 11, 1887.

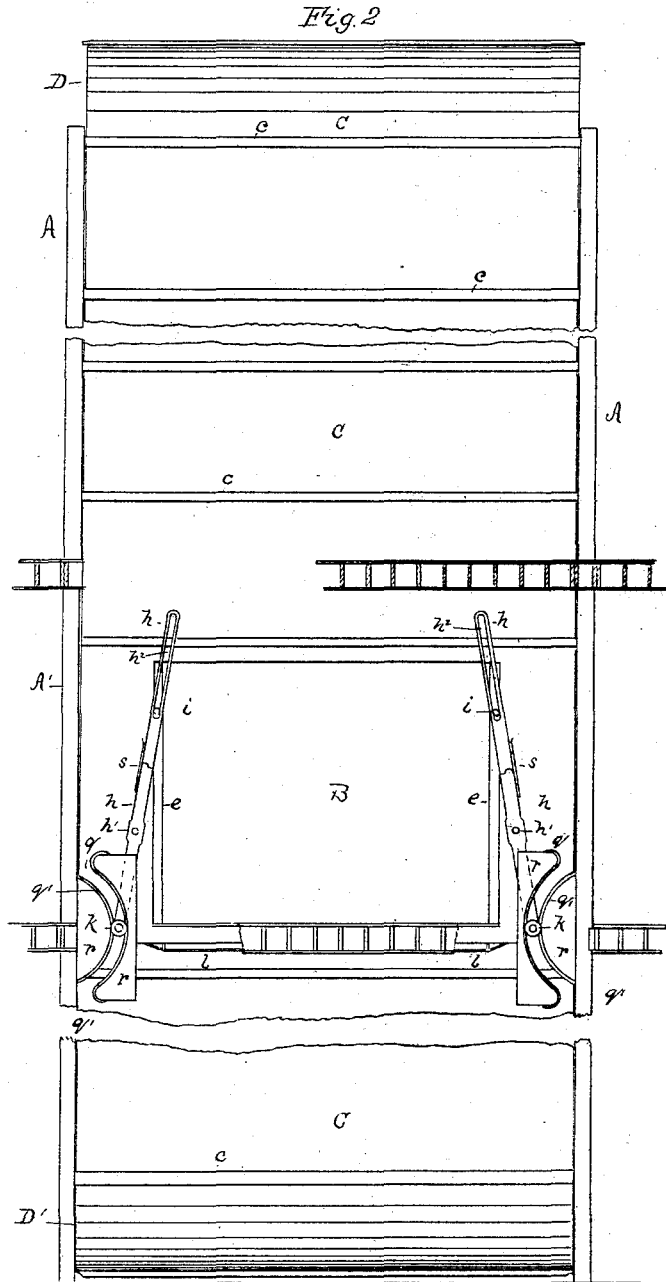
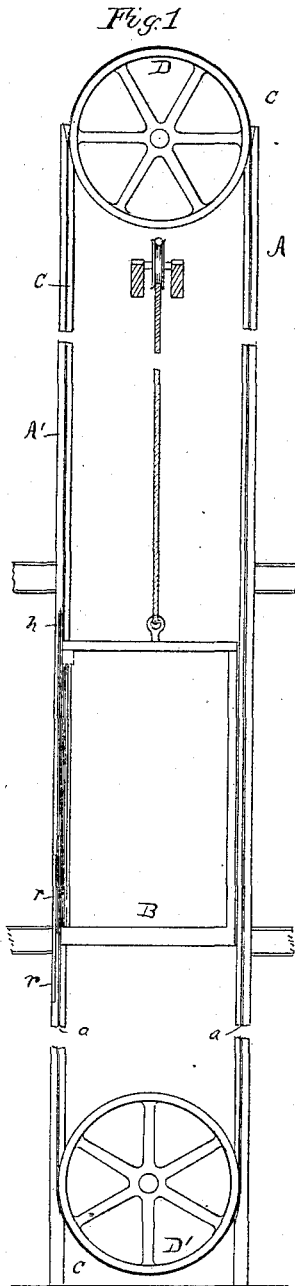

Witnesses

J. H. Reed
J. J. James

Inventor

Alexander Miles

By his Attorney

P. H. Gunkel

(No Model.)

3 Sheets—Sheet 2.

A. MILES.
ELEVATOR.

No. 371,207.

Patented Oct. 11, 1887.

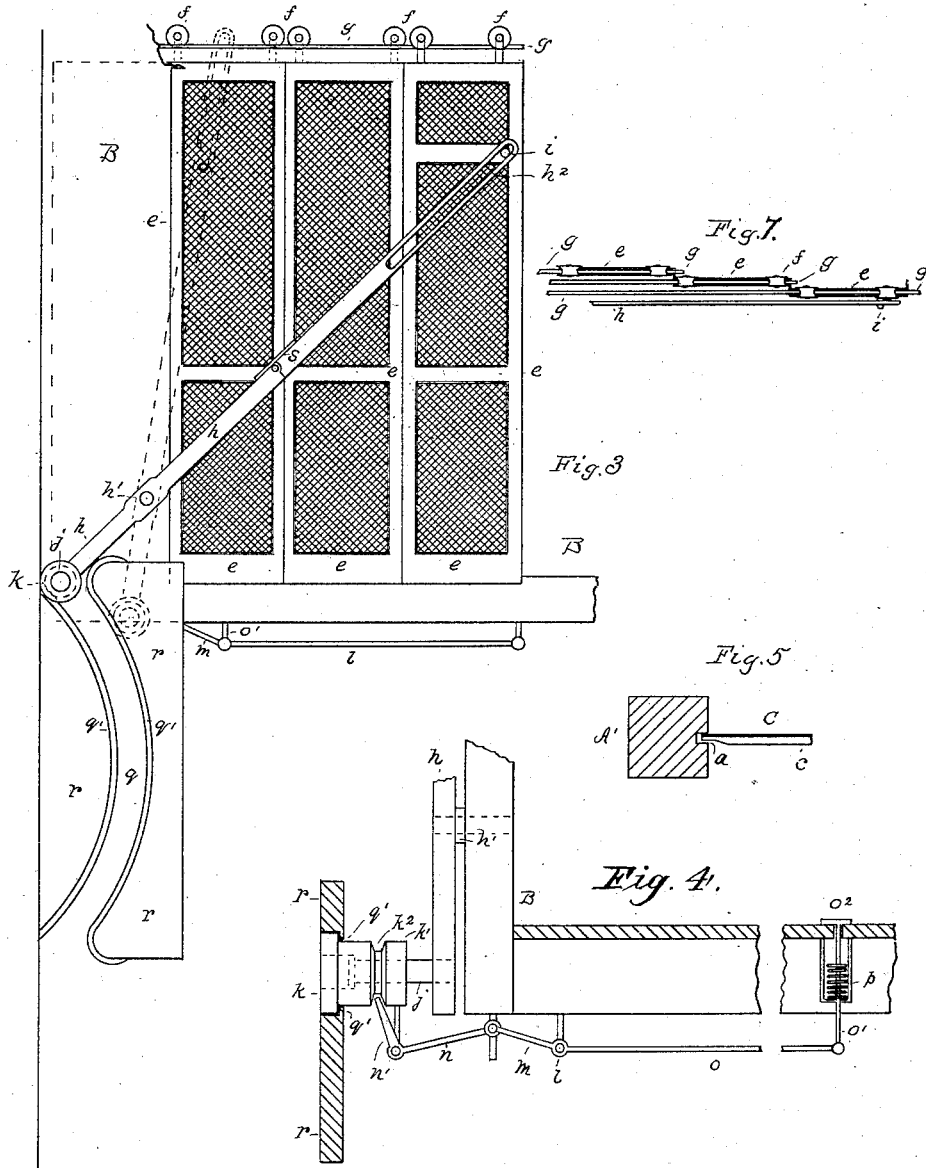

Witnesses
J. N. Reed
Wm. P. Fog

Inventor
Alexander Miles
 By his Attorney
P. H. Gunkel

(No Model.)

3 Sheets—Sheet 3.

A. MILES.
ELEVATOR.

No. 371,207.

Patented Oct. 11, 1887.

Fig. 6

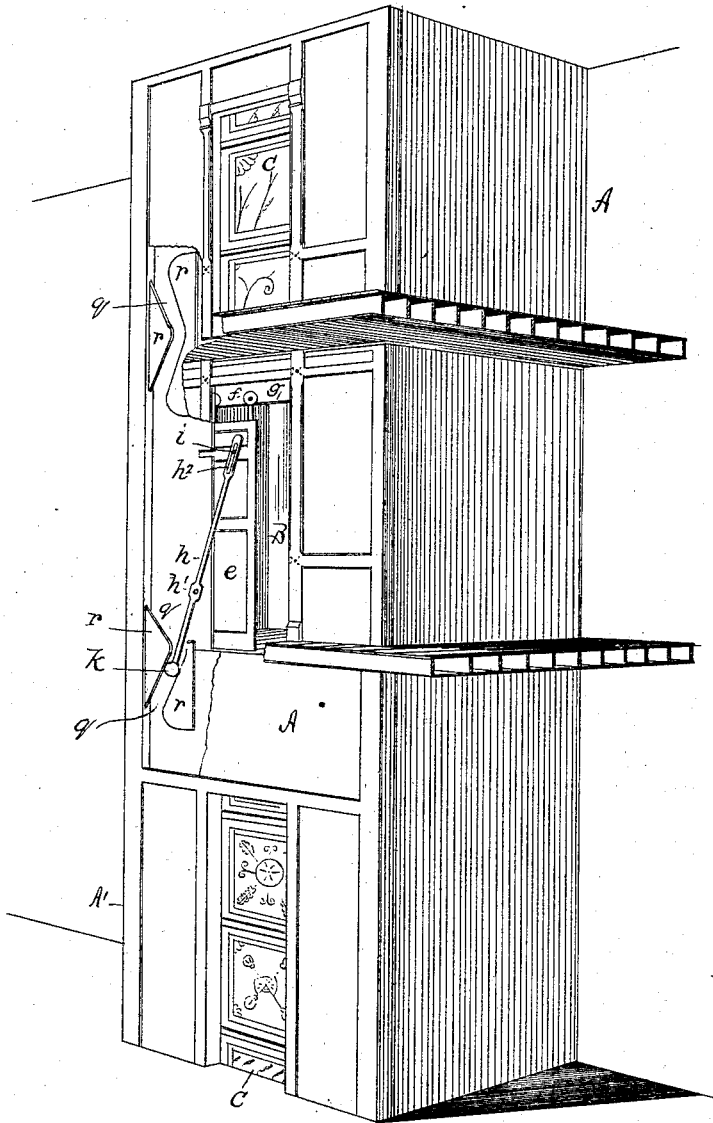

Witnesses

J. H. Reed
J. J. James

Inventor

Alexander Miles

By his Attorney

P. H. Guindel

UNITED STATES PATENT OFFICE.

ALEXANDER MILES, OF DULUTH, MINNESOTA.

ELEVATOR.

SPECIFICATION forming part of Letters Patent No. 371,207, dated October 11, 1887.

Application filed May 23, 1887. Serial No. 239,664. (No model.)

To all whom it may concern:

Be it known that I, ALEXANDER MILES, a citizen of the United States, residing at Duluth, in the county of St. Louis and State of Minnesota, have invented certain new and useful Improvements in Elevators, of which the following is a specification.

My invention relates to mechanisms for closing the openings to the shafts of passenger and freight elevators and for operating the doors of the elevator-cages.

The objects of the invention are, first, to provide mechanism operating automatically to close the shaft-openings above and below the elevator-cage, and so preclude the possibility of danger by reason of such openings being left unclosed through negligence; and, second, devices operating automatically by the movement of the cage to open and close the cage-doors when set by an operator to be in engagement at any desired floor. The first of these objects is accomplished by means of a flexible belt having its ends attached to the cage and running over drums at the top and bottom of the shaft, and the second by means of levers pivoted to the cage, having one of their ends connected to a door and the other ends carrying rollers which are engaged in curved grooves provided in the corners of the shaft at the several floors, and devices provided in the cage for enabling an operator to throw the rollers into or out of engagement at will. These objects are attained by the mechanisms illustrated in the accompanying drawings, in which—

Figure 1 is a side elevation of an elevator shaft and cage containing my improvements. Fig. 2 is a front elevation of the same. Fig. 3 is a detached view of one of the cage-doors and its operating devices. Fig. 4 is a detail of the devices for sliding the roller-wheels carried by the levers to and from positions to be engaged in the grooves. Fig. 5 is a cross-section of one of the uprights of the shaft, showing the beltway and a portion of one of the belt cross-strips in it. Fig. 6 is a perspective view of an elevator shaft and cage provided with the improvements, but having a single cage-door; and Fig. 7 is a top view of the sliding doors and their tracks.

In the several views, A designates an ele-

vator-shaft, in the corners of which are uprights A'.

B designates the usual cage, operated by any of the applications usual for such purposes.

C is a belt of any suitable fabric or material (such, for instance, as canvas, as shown in the drawings, or woven-wire fabric) having sufficient flexibility to run over drums. The belt is passed around drums D D' or over suitable rollers of any character at the head and bottom of the shaft, and one of its ends is attached to the top of the cage at the front and the other end to its bottom at the front. Across the face of the belt are strips *c*, whose ends slide in grooves *a*, formed in or on the uprights A' at the corners of the shaft. These strips keep the fabric stretched laterally and afford means for guiding it in the grooves. The front of the shaft has openings at the several floors, and these openings are at all times kept closed by the belt, except that at the floor at which the cage happens to be, and thus all danger of accidents by reason of doors in the shaft being carelessly left open, as is frequently the case in elevators as ordinarily constructed, is avoided.

The cage doors *c* are preferably made in two or more sections hung on wheels *f*, that run on separate tracks *g* in the upper portion of the cage, so that the sections may slide past one another when pushed outward, as shown in Figs. 3 and 7, and slide together to occupy but small space, as shown in Fig. 2. By such arrangement the greater portion of the cage-front can be thrown open to admit passengers or freight, and in passenger-elevators required to do rapid service but little time need be consumed in filling or vacating the cage.

To operate the doors levers *h* are fulcrumed at *h'* to the front of the cage and have their upper ends connected to the outer door-sections by pins *i*, passed through long slots *h''* in the levers, and on the lower end of the levers are spindles *j*, projecting outwardly from the levers and carrying roller-wheels *k* on their ends. The wheels are attached to sleeves *k'*, having grooves *k''*, and the wheels and sleeves are capable of being made to slide as well as rotate on the spindles. A rock-shaft, *l*, is hung beneath the cage-floor, and to it are attached arms *m*, to which are connected piv-

oted levers n , having angular arms n' , which engage in the grooves k^2 of the sleeves k . The rock-shaft is operated by means of a lever, o , extending under the cage, and having an upright arm, o' , projecting through the cage-floor, and a foot-piece, o^2 , on its end. The devices are operated to slide the roller-wheels k outward by the depression of the arm o' by the foot of an operator, and they are returned to normal position by the force of a spring, p , that is compressed by the depression of the arm o' . When the roller-wheels are thus thrust outward to the extreme limit of their movement, as in Figs. 3 and 4, they are in position to engage in the grooves q . These grooves or curved ways are provided in a plate or plates, r , secured to the inside of the front of the shaft A, and are of suitable curved form, and are so arranged that as the roller-wheels are made to travel in them by the ascent or descent of the cage the doors will be thrown wide open by the levers by the time the cage-floor arrives at the level of the building-floor, and the rollers will then also be at the extreme limit of the curve of the grooves. When in that position, as in Fig. 2, and the cage is started in either direction, the rollers, following the backward curve of the grooves, will cause the levers h to again close the doors. The grooves have flanges q' to prevent the roller-wheels from slipping out when in the grooves.

The levers h are made of two parts, hinged together, and backed by springs s , of proper strength to enable the levers to perform their functions, but which will yield when the doors meet unusual resistance, thus avoiding serious hurt to a person caught between the doors, and also lessening the liability of breakage of the operative parts.

In use, the doors being closed and the cage made to ascend or descend, as it approaches the floor at which it is desired to stop, the operator has but to place his foot on the foot-piece o^2 to cause the lever-rollers to enter the grooves q and the doors to be fully opened by the time the cage reaches the floor. It will be understood that unless the lever-rollers are thus thrown into position for engagement they will not enter the grooves and the doors will not be opened.

In Fig. 6 is shown a cage having only one door; but the devices for operating it are substantially like those heretofore described.

Having fully described my invention, what I claim, and desire to secure by Letters Patent, is—

1. In combination, an elevator-shaft having door-openings, a cage provided with doors, a belt having its ends attached to the upper and lower portions of the cage-front, and drums for said belt at the top and bottom of the shaft, substantially as set forth.

2. In combination, an elevator-shaft having door-openings, a cage and its operating mechanism, a flexible fabric operated by the cage to close the shaft-openings above and below

the cage, a sliding door in the cage, and devices, substantially as described, for operating the door as the cage arrives at a shaft-opening and closing the door as the cage departs, substantially as set forth.

3. The combination, with an elevator-shaft having door-openings at the several floors of a building, of a cage and its operating mechanism, drums at the head and foot of the shaft, a belt thereon having its ends attached to the cage-front, sliding cage-doors, levers connected thereto, fulcrumed to the cage, and carrying rollers at their free ends, and curved ways in the shaft for said rollers, whereby the levers may be made to open and close the doors, substantially as described.

4. The combination, with an elevator-shaft having door-openings and a cage having sliding doors, of levers connected to said doors and fulcrumed to the cage, spindles attached to the free ends of the levers, sliding roller-wheels thereon, curved ways in the shaft for guiding said wheels, a rock-shaft and levers capable of being operated to slide said wheels to positions to enter said ways, and a retracting-spring for holding the wheels normally away from such positions, substantially as set forth.

5. The combination, with an elevator-shaft and a cage having a sliding door, of a lever for opening and closing the door, a spindle on the free end of the lever, carrying a roller-wheel, curved ways at intervals in the shaft for engaging said wheel, and levers arranged to be operated from within the cage to slide the wheel on its spindle, whereby an operator may, at will, cause the roller-wheel to enter said ways, for the purpose set forth.

6. The combination, with an elevator-shaft having door-openings, of a cage having a sliding door or doors and mechanism operated by the cage movements to open or close the door or doors at the desired shaft-door opening, substantially as described.

7. In an elevator, the combination, with a cage, of sliding double doors therein, and mechanism actuated by the cage movements for simultaneously opening and closing both doors, substantially as set forth.

8. In an elevator-cage having a sliding door, the combination, with such door, of a lever having a hinged portion and a spring backing said hinge, for the purpose set forth.

9. The combination, with an elevator-cage, of a door or doors formed of sliding sections, hangers, rollers, and separate tracks for such sections, for the purpose set forth.

10. The combination, with the levers for opening and closing the cage-doors and the sliding roller-wheels carried by said levers, of the curved ways therefor, having flanges for preventing withdrawal laterally of the wheels when in the ways, for the purpose set forth.

ALEXANDER MILES.

Witnesses:

S. L. SMITH,
PHILO STEWARD.